



### Features

- ☆ To filter dust and other small particles from the vacuum flow.
- ☆ Reduces the risk of operation breakdown or stoppage in the pump.
- ☆ Replaceable filter element.
- ☆ Available with special filter element with increased filter area.

### Specifications

		ABF-10	ABF-15	ABF-20	ABF-25	ABF-40
Pressure range	bar	-1~0bar				
Material		PA, PC, PE				
Temperature range	°C	-20~80				
Removal efficiency	μ m	10				
Weight	g	70	168	170	424	550
Flow nominal	l/m	150	900	900	2520	5100
Volume internal	cm <sup>3</sup>	45	195	205	495	675
Filter area	m <sup>2</sup>	0.003	0.010	0.010	0.019	0.023

### How to Order

#### ABF – 10

①

① Model	
ABF-10	G3/8"
ABF-15	G1/2"
ABF-20	G3/4"
ABF-25	G1"
ABF-40	G1 1/2"

### Dimensions (mm)

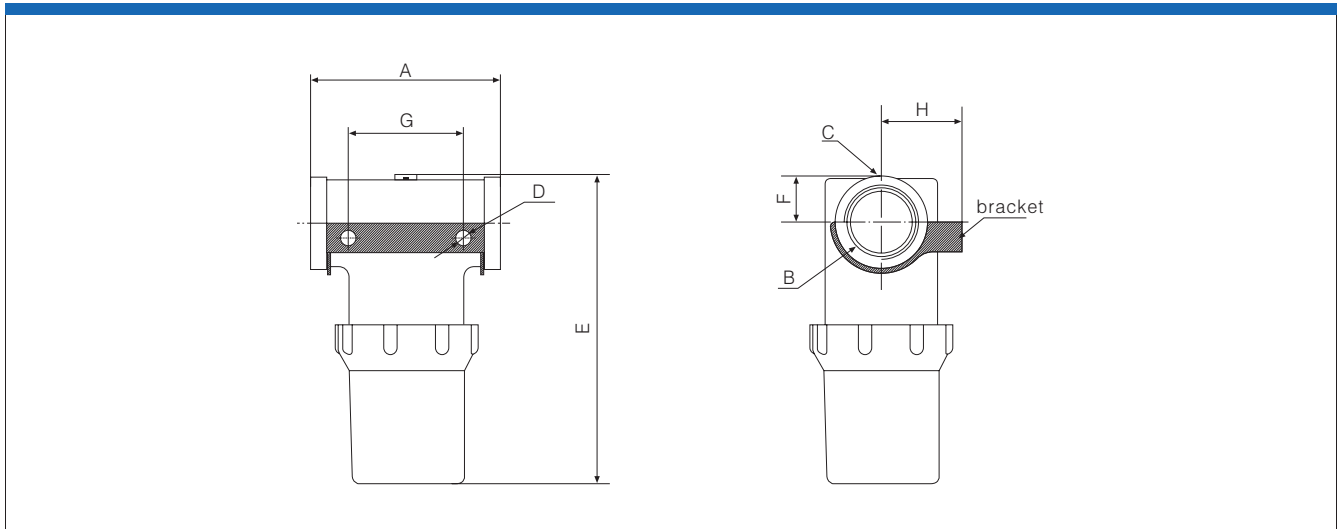

Model	ABF10	ABF15	ABF20	ABF25	ABF40
A	76	91	91	126	126
B	2-G3/8"	2-G1/2"	2-G3/4"	2-G1"	2-G1 1/2"
C	NPSF1/8	NPSF1/8	NPSF1/8	NPSF1/8	NPSF1/8
D	2-Φ6.5	2-Φ8.5	2-Φ8.5	2-Φ10.5	2-Φ10.5
E	71.3	131.5	138.5	167	209.5
F	14	16	18.5	23	31
G	45	50	50	80	80
H	27	40	40	56	56

### How to Order

#### F – 10

①

① Model		
F10		G3/8"
F20		1/2" & 3/4"
F25		1"
F40		1 1/2"

Remarks: Filter element 1/2" & 3/4" (special), 1 1/2" (special) are optional. Their removal efficiency is 5

### Technical data of filter element

		F-10	F-20	F-25	F-40
Weight	g	7	26	50	74
Filter area	m <sup>2</sup>	0.003	0.010	0.019	0.023
Removal efficiency	μm	10	10	10	10